

HEIMANN Sensor GmbH		Product Specification: Thermopile Sensor HTS-E21-F3.91/F4.26
Author(s): W. Leneke, J. Schieferdecker	Rev.: R 0.1 / 04.08.2005	Page 1 of 6

Specification Thermopile Sensor HTS-E21-F3.91/F4.26

R 0.1

Author(s):

W. Leneke, M. Simon

Revision History

Version	Date	Remarks
R 0.1	04.08.2005	1. Draft of HEIMANN Sensor GmbH

HEIMANN Sensor GmbH		Product Specification: Thermopile Sensor HTS-E21-F3.91/F4.26
Author(s): W. Leneke, J. Schieferdecker	Rev.: R 0.1 / 04.08.2005	Page 2 of 6

1. Purpose, Scope

The new thermopile infrared sensor from Heimann Sensor, comprising a new type CMOS compatible sensor chip plus a thermistor reference chip, features good sensitivity, small temperature coefficient of sensitivity as well as high reproducibility and reliability.

The sensor will be available in standard transistor outline packages in different sizes, equipped with an IR transmitting filter window (transmission curve as shown below).

2. Absolute Maximum Ratings

Parameter	Symbol	Limits			Units	Conditions
		Min	Typ.	Max		
storage temperature		-40		120	°C	
operating temperature		-20		120	°C	

3. General and Electrical Parameter Thermopile

Parameter	Symbol	Limits			Units	Conditions
		Min	Typ.	Max		
element size			1.2*1.2		mm ²	absorbing area
resistance	R _{TP}	69	84	112	kΩ	-40°C to 100°C
TC of resistance			0.02		%/K	25°C
signal voltage channel 3.9	V _S	60	90	115	μV	Heimann Sensor test set-up "F1": IR source, 6V, 3Hz, distance 15mm
signal voltage channel 4.26	V _S	95	120	145	μV	Heimann Sensor test set-up "F1": IR source, 6V, 3Hz, distance 15mm
noise voltage	V _{RMS}		37		nV/√Hz	r.m.s., 25°C
time constant	τ		10	13	ms	

HEIMANN Sensor GmbH		Product Specification: Thermopile Sensor HTS-E21-F3.91/F4.26
Author(s): W. Leneke, J. Schieferdecker	Rev.: R 0.1 / 04.08.2005	Page 3 of 6

4. General and Electrical Parameter Thermistor

Type	Thermistor 100kΩ					
Parameter	Symbol	Limits			Units	Conditions
		Min	Typ.	Max		
resistance	R _{TH}	95	100	105	kΩ	25°C
BETA-value	β	3900	3940	3980	K	25°C/50°C

T / °C	Rth_min / Ohm	Rth_nom / Ohm	Rth_max / Ohm
-30	1557900	1655000	1753100
-25	1163320	1234000	1306680
-20	875826	928700	981974
-15	665010	704500	744190
-10	508730	538500	568370
-5	392108	414600	437292
0	304466	321700	338934
5	238072	251400	264728
10	187444	197800	208056
15	148568	156600	164632
20	118404	124800	131096
25	95000	100000	105000
30	76537	80630	84713
35	62032	65380	68738
40	50543	53310	56077
45	41386	43680	45984
50	34070	35980	37890
55	28174	29770	31366
60	23405	24750	26095
65	19536	20670	21804
70	16383	17340	18297
75	13788	14600	15422
80	11653	12350	13047
85	9890	10480	11080
90	8421	8930	9444
95	7197	7635	8076
100	6172	6551	6935

HEIMANN Sensor GmbH		Product Specification: Thermopile Sensor HTS-E21-F3.91/F4.26
Author(s): W. Leneke, J. Schieferdecker	Rev.: R 0.1 / 04.08.2005	Page 4 of 6

5. Filter Characteristics

Filter F3.91					
Parameter	Limits			Units	Conditions
	<i>Min</i>	<i>Typ.</i>	<i>Max</i>		
Center wavelength (CWL)	3.87	3.91	3.95	µm	
Half power bandwidth (HPB)	70	90	110	nm	
HPB/CWL		2.3		%	
Peak transmittance	76			%	
Blocking		$T_{\text{average}} < 0.1\%$		%	from UV to band pass
		$T_{\text{peak}} < 1\%$		%	from UV to band pass
		$T_{\text{peak}} < 1\%$		%	from band pass to 12µm

Filter F4.26					
Parameter	Limits			Units	Conditions
	<i>Min</i>	<i>Typ.</i>	<i>Max</i>		
Center wavelength (CWL)	4.05	4.26	4.51	µm	
Half power bandwidth (HPB)	160	180	200	nm	
HPB/CWL		4.2		%	
Peak transmittance	73			%	
Blocking		$T_{\text{average}} < 0.1\%$		%	from UV to band pass
		$T_{\text{peak}} < 1\%$		%	from UV to band pass
		$T_{\text{peak}} < 1\%$		%	from band pass to 12µm

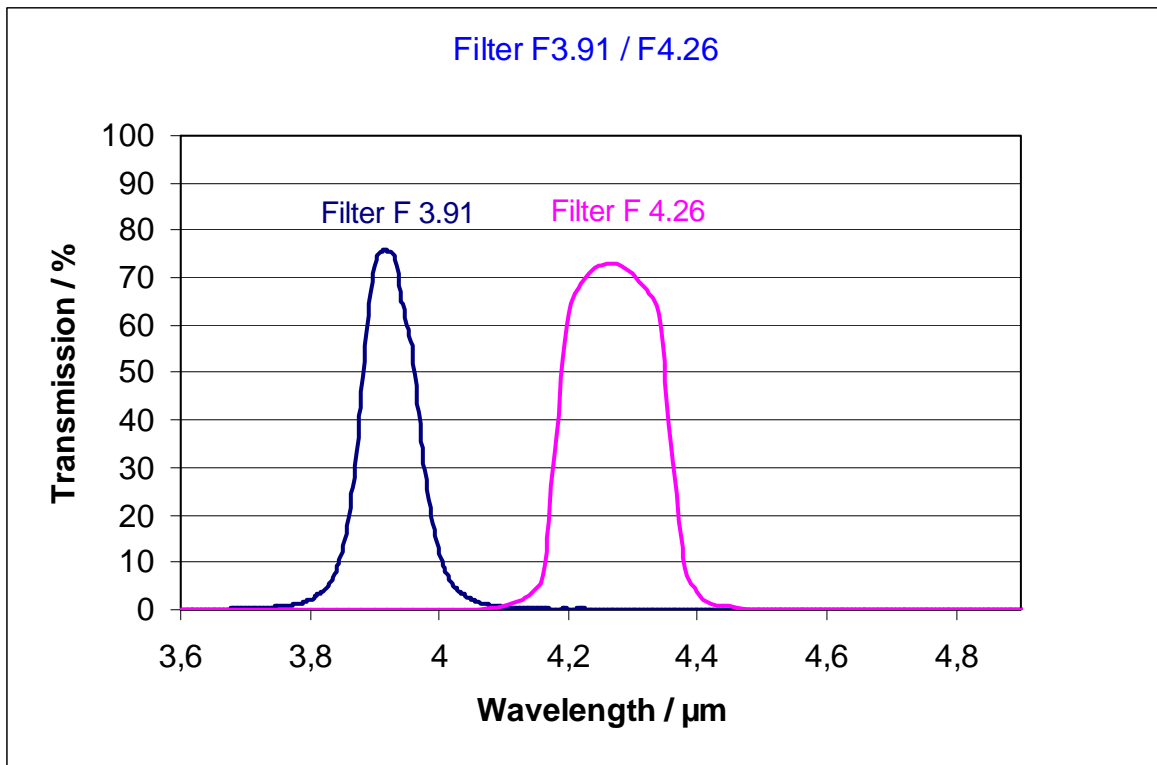

6. Drawing and Pin Assignment

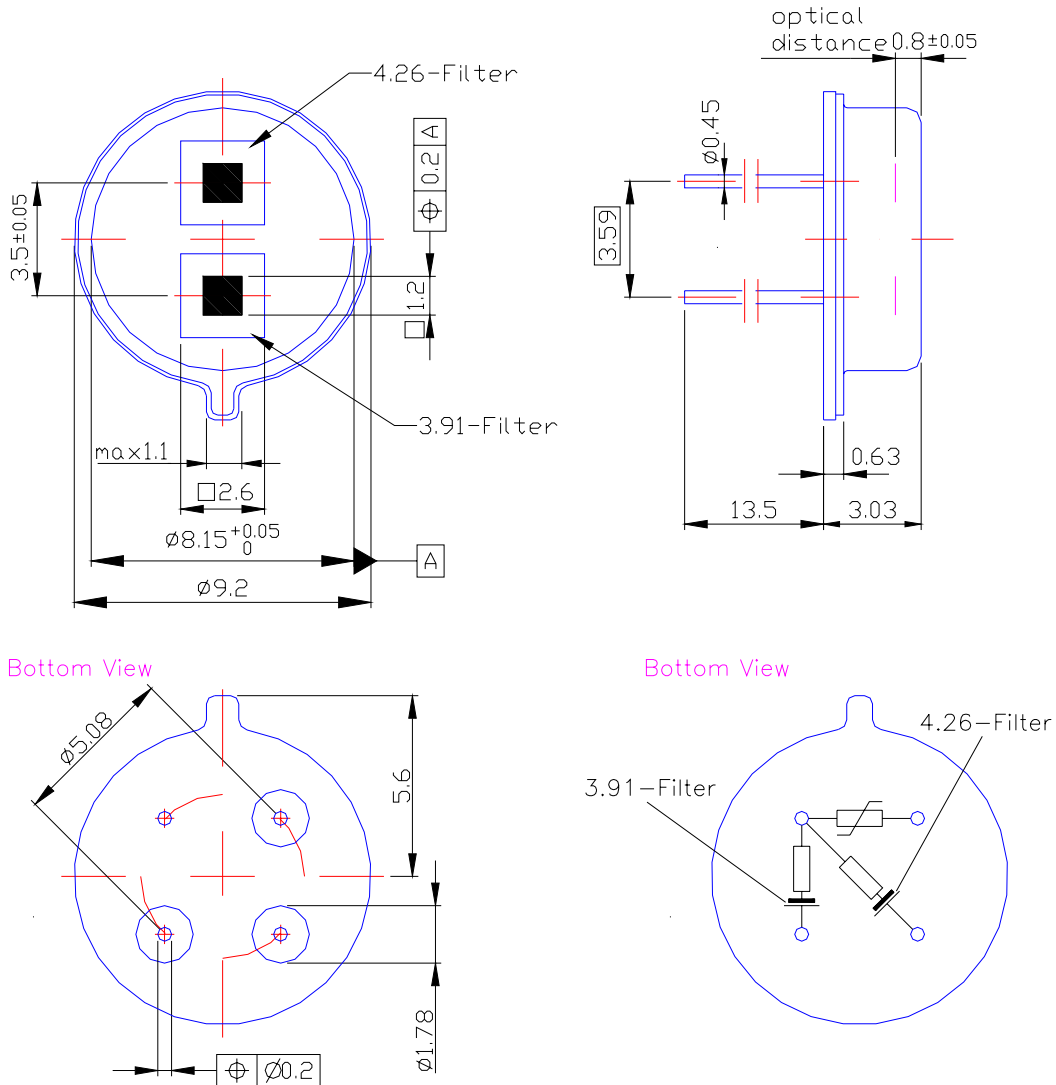

7. Liability

Changes or modifications at the product which haven't influence to the performance and/or quality of the device haven't to be announced to the customers in advance. Customers are requested to consult with Heimann Sensor representatives before the use of Heimann Sensor products in special applications where failure or abnormal operation may directly affect human lives or cause physical injury or property damage. The company or their representatives will not be responsible for damage arising from such use without prior approval.